

Motorola Micor receiver by Karl Shoemaker



Introduction:

The purpose of this project is to promote good communications audio, starting with repeater/systems. Better practices are used for all SRG projects. Some of these will be covered in this document. This document is written to include interested people in serious construction of a quality product. Its rather technical however, if you have a basic electronics background with some repeater building experience this should not be an issue. Understanding schematic drawings is required. Allow plenty of time to construct each unit, especially the first one. No free technical support is available however, some printed documents are available on an occasional bases, for a modest cost for P & H. The project is designed for amateur radio (not commercial) and is open for discussing, changes and improvements without notice. Should you feel qualified you are welcome to deviate from the Author's design. Images in this document may be used to illustrate a point only and may have been taken at different stages of research and development therefore, may not show the end "product" in some cases. From OEM specifications, no performance or reliability degradation was observed from the modifications discussed in this document.

In many cases there are not additional people to help out with the system maintenance. Therefore, some of the SRG design features to be added and/or modified is for one person working on the equipment.

Overview:

For this project the Motorola Micor receiver in the amateur 2-meter band is used. This project is for the remoted user input access points for Spokane Repeater Group's 2-meter repeater. It's interfaced with external (downlink) equipment for positive and full-time connection with the rest of the system.

Motorola, Inc. made several models of LMR transceivers. Some of them were built with transmitter and receiver units put together as a single unit, either in mobile or (base) station configuration. One was the "Micor" built around the 1970's through the 1980's. They performed with excellence and would last many years in commercial service. Even though they are 30 years old they are still in service. With the exception of an occasional (dried) electrolytic capacitor needing replacement they continue to work well for amateur service. This for two main reasons; one, they are very cheap (or free) to obtain for amateur service and two, they are set up for the "normal" +/- 5 KHz channel deviation/modulation, while current commercial systems have migrated to the "narrow" band of half of this. Although there may be some unknown "SP" receivers and other sub-bands and chassis types, this document is focused on the more commonly known models in the VHF "Hi-Band" 132~174 MHz.

Because the Micor Tx and Rx units can be easily taken apart and configured for separate units, this is ideal for SRG's repeater design. In the early days of the system build-out, by the Author, the micor receivers were used for the outlying coverage areas, such as "Wenatchee" and "Omak". They were various type receivers (mobile and base). In the future (after research of 2008-13) it's planned to continue setting up these receivers for the "Spokane" area as well with the "Spectra-Tac" type for the most part. Earlier builds will continue in service for their lifetime therefore, this document is also support for those as well as the new builds.

Even though all of them are negative ground, there are some factors you need to be aware of before using these receivers for amateur repeater service. For example, this receiver uses a (noise) type squelch circuit to keep the speaker and/or line (AF) output silent during no activity. During activity the audio path needs to turn on, thus providing activity to a controller or associate transmitter's audio circuit. The squelch also needs to signal such a controller or transmitter for its PTT input. These and other factors are covered in this document.

Note: In this document, any font in blue indicates a guess and/or not verified at the time of publication.

Acronyms, Definitions, semantics and Theory basics for Telecommunications:

Some of this material may not be popular reading for hobbyist however, is necessary to maintain a complete understanding of the project at hand. "Layman" terms will be used, when practical, to make reading a little more "fun", at the expense of occasional rough calculations and other "rounded" off math figures. To be very clear on this philosophy, we will start with the basics. Humans wish to communicate since the cave-man days with grunts. A few million years later with smoke signals. A hundred years or so ago with wired telegraph (1800's) and wireless telegraph (1900's). In the 20th century voice finally was realized. In the 21st century better sounding, analog voice, then data and digital voice was realized. Only analog communications/transmission for Land Mobile Radio (LMR) will be covered in this document.

Radio systems send intelligence (voice, data, etc.) by modulating the originating transmitter and decoding (detecting) this modulation at the far end receiver back to something usable to be understood. How well this is understood depends greatly on how well the system is set up. Just about anyone can "throw" a system together to make it work, somewhat.

Amateur radio can develop the art of radio and improving operating practices in this area. This can set a good example for others, including the commercial industry, to what some amateur radio systems are capable of doing and to provide public service communications in time of need. This includes the technical side, to produce a high performance repeater and/or link.

A "repeater" is a generic term for user's signals to be received (input) and retransmitted (output). This greatly increases radio coverage, for a single-site, conventional repeater. Extended (user) coverage can be realized by linking several repeaters together. Further user coverage can be realized with a voter system and simulcasting as well in analog systems.

Most radio systems in the VHF, UHF (and microwave) are line-of-site for the radio paths. On the ground a path has limited range because of obstructions which attenuate signals. From high (remote) sites greatly increase this because most of the obstructions are gone.

A "link" is a one-way transport method for repeater support, such as the remote receivers on a voting system. For example, a repeater's (input) receiver may need to be "downlinked" to a central control point, such as a voter or connection to the outside world (telephone, internet, etc.). From this control point the system output can be "uplinked" back up to a high transmitter (output) for the users to enjoy wide coverage of such a system. In this case would be a multiple site repeater (system of links, etc.) In conclusion, three factors improve a conventional analog radio system:

- Repeater; to "relay" user signals.
- High location; get away from obstructions.
- Voter system; easy user access, especially with portable-low power subscriber units (users).

A typical (commercial) system uses the audio portion 300Hz~3KHz for repeaters and links. With several links this produces "tinny" and distorted audio. In some cases squelch and signaling circuits produce signals that are annoying and fatiguing to listen to. Because of user tolerance and ignorance this sets a (bad) precedence of what a system is expected to be. This document covering system performance will be somewhat different. The Author's design and specifications call for a better way, and is practiced in all SRG projects such as this one. For example, "flat" audio, better squelch and other signaling practices are utilized. This keeps a large system nice to listen and operate and may set examples for other groups to improve their systems. It also calls for good technical management.

For one, technician organization and discipline is necessary. Plan on what you want to do for a system design and stick to it. Force yourself to keep good practices. One good practice is to establish level references. Some call these "benchmarks" or "baselines". While old methods used linear (microvolts, watts, etc) units of measure, design of this project and document uses logarithmic units. Once accustomed, it's easier to see the entire picture this way, when designing a system or checking system performance and keeps the guesswork out of troubleshooting a subtle level problem. References can be expressed with a few acronyms.

Test Tone Level and Test Level Point:

Test Tone Level (TTL) is referenced to tone that modulates a channel or path 100%. For a testing or aligning a LMR transmitter, receiver or path this would be a 1 KHz (1004 Hz for telephone work) for a FM (frequency modulation) system. Test Level Point (TLP) refers to a measurement point (normally on equipment) in reference to TTL. TLP provides easy reference to any parts of the system for measurement and alignment. 0 dbm is referenced to 1 milliwatt at 600 ohms. A 6-dB drop in (voltage) level would reduce the modulation in half, and so on.

Levels are stated in transmit-receive (Tx-Rx) order. Therefore, an audio (Voice Frequency) "drop" TLP of 0/0 would mean a Tx TLP of 0-dbm, Rx TLP of 0-dbm. For example, a transmitter AF input with a TLP of 0 dbm, with a TTL of 0 dbm tone input, would fully modulate the system. If the far end receiver was set up the same, its output would be a 0-dbm tone as well.

Absolute levels are specific-measured (operating) levels, not to be confused with TTLs. Sometimes operating levels are not at TTL. In this case, a level would be so many db "down" from TTL, or just called "xx down". For example, CTCSS (sub-audible) tones normally are 18 db down. (1/8 deviation from voice, or 18 db down from maximum voice and/or TTL).

To avoid technician confusion two sets of numbers are sometime used in diagrams and on the physical equipment's ports or I/O connections. Non-parenthesis figures are (absolute/actual) fixed operating levels, and as mentioned before, may be at different levels from the TTLs. Figures in parenthesis are the TLPs, which is explained below.

Levels below 0 dbm are negative, while above are positive. Take this into consideration when working with system gains or losses. Normally, the negative levels have a minus in front of the number, while positive (optionally) have a plus sign. This is also true for absolute levels (as opposed to TTLs). This method is used for most any AC frequency (audio or RF). For example, many transmitters run a +42 dbm while most receivers' sensitivity run a -117 dbm for 20 dB quieting.

Other terms:

RF or AF ports at the **Top Of Rack** are considered "TOR". This is all equipment in/on the station's cabinet or rack. External equipment from TOR is later figured for a system performance (losses or gains). This may be RF lines, a combiner system or tower antenna(s). TOR levels are referred in the order of the transmitter and receiver (Tx and Rx, respectively).

Single digit numbers of "1" and "0" in brackets (" [] "), are not to be confused with TLPs. In this case these 1s and 0s identify the logic state of a gate, or other TTL/CMOS I/O driver circuit, and so forth. Another aid to avoid confusion between logic states and a TLP is that the latter normally would have a "+" or "-" before the number (as earlier mentioned). For example, a TLP of -14.8 is the audio input controlled by a logic gate of [1], being a normal logic "high". One last word on the logic state; The brackets indicate a state in normal standby/no activity condition. As a side note, "TTL" mentioned above has nothing to do with "TTL logic", a type of IC series.

Most "TIMM"s and AC voltmeter scales are in "dbm". When measuring across a circuit you may need to have the meter in bridge mode, being medium impedance as not to load down what you are measuring. In such cases a more accurate term of level would be "dBu". Having said this, dbm reading in bridge mode is still understood by most, for a specific (absolute) level measurement using log10 based numbers.

The term "COR" came from the old tube days of "Carrier Operated Relay" whereas, a tube receiver had a point, when its squelch opened, a tube (switch/valve) drew current through a relay's coil, to give some contact closure, to key the associated repeater's transmitter. Repeater stations in the early years were called "Relays" whereas, the station would "relay" a signal rather than "repeat" a signal.

As the solid state technology came in the later 1960's the COR term stayed with repeater operation. In addition, most modern equipment no longer had a mechanical "relay" used. Perhaps a more accurate term would be "Carried Operated Squelch" or "Carrier Operated System" (COS). Both terms are correct and this gets down to semantics or content of a discussion:

- Modern technology used in the LMR field by amateurs and professionals alike.
- Recent repeater product terminology and it's manuals.
- To avoid reader confusion; since they may expect the term of "COR".

After careful consideration it was decided to stay with the term "COR". Therefore, this and other SRG documentation will reflect this decision.

"CS" will be reserved to describe "Carrier Squelch" as a receiver's mode of operation, versus "TS", "PL" or "CTCSS" to describe a "Tone Squelch", "Private Line" or "Continuous Tone Coded Squelch System".

"SDI" means Signaling Decode Indicator (or Input). It's also similar to a CTCSS line out of a tone decoder. "HUB" means Hang Up Box. Motorola's uses a "closed loop" for mobiles and base station control. "AND squelch" means it takes both carrier + tone to activate a COR board, transmitter or system. AND squelch is also referred as a variable sensitivity squelch whereas, the squelch setting affects activity threshold. An "OR" squelch does not whereas, it "bypasses" whatever squelch setting, using only tone to keep it active (once the squelch is open on startup reception). More is discussed, later in this document.

Push To Talk:

The term "PTT" came from a button on a radio's microphone. For this documentation PTT will describe an active going "low" for DC functions, such as transmitter keying ("PTT Input"). It also will describe a receiver's COR line driving a NPN transistor, with the open collector being "Receiver PTT Out", or just "PTT Out". "PTT 1" will describe this function however, with a buffer, such as the output of the cor/af board, which changes state for user signal change of status. This function would be used for audio switching, such as auto-patch audio routing. "PTT 2" will describe a buffered, and "hangtime/tail" output of the cor/af board, to keep a repeater's transmitter keyed up (AKA tail) for normal back-and-forth conversations of the users of such system(s). One or both types of PTTs may be time-out controlled.

PM/FM: (for a transmitter)

Frequency modulation is the common way to send intelligence in the LMR analog world. FM is also referred to "deviation" (of the carrier, at an audio rate). There are two ways to frequency modulate a transmitter, phase modulation (PM), AKA indirect, or (direct or true) FM (frequency modulation). PM is the easiest design with good frequency stability however, lacks audio response. PM has "natural" pre-emphasis which works well for LMR standard. On the other hand, (direct) FM has much better response (flat audio) at the cost of more complex engineering to keep stability. Also, FM needs additional pre-emphasis. With modern synthesized/PLL transmitters this is major consideration. However, later technology-design has allowed direct FM to perform well in LMR systems.

The MI (modulation Index) for a PM signal is always changing, especially for voice traffic. MI is mentioned because FM causes side bands to be created above and below the carrier and takes up bandwidth on a particular frequency, or sometimes called a "channel". Modulation and deviation are the same results when talking about FM. Maximum deviation of 5 KHz means 5 KHz above the center frequency and 5 KHz below the center frequency, making a total bandwidth of 10 KHz possibly including side bands. Radio technologies have different bandwidth standards (for maximum deviation) such as:

- FM radio broadcast of 75 KHz
- TV (analog) aural of 25 KHz
- Legacy cellular of 12.5 KHz
- Legacy commercial/government (LMR) VHF-UHF of 5 KHz (and most amateur).
- Current commercial LMR of 2.5 KHz
- Point-point microwave using (legacy) frequency division multiplexing about 5 MHz, in many cases.

While its good to be aware of these different bandwidth standards only amateur radio standards will be covered in this document. Crowded parts of the U.S. and abroad may use the “narrow band” standard of +- 2.5 KHz. It’s believed the reasoning behind the narrow band is less adjacent channel interference at the cost of lower performance in some cases. The Pacific Northwest VHF bands are still blessed in 2020 with the 5 +- KHz standard and is the standard for SRG projects such as this one.

A quartz crystal is normally used to control the frequency of an oscillator. A variable capacitor across the crystal can fine-adjust the frequency in the form of “warping” it. The fundamental crystal frequency will be converted by multiplying its frequency to obtain the (final) operating frequency. For example, a typical LMR VHF transmitter would be 12 times; or a tripler, driving another doubler, driving a final doubler. ($F_c = 12 \text{ MHz} \times 3 \times 2 \times 2 = 144 \text{ MHz}$). It’s then amplified to a usable level for transmitting over the air.

Transistors and diodes have a P-N junction inside the case. The former can be used as an amplifier or switch with a potential (voltage) applied to create current flowing in the forward direction (against the schematic diagram arrow).

They also can be used as a variable capacitor. The P-N junction on either device has a “space” in the middle in the form of capacitance called the “depletion zone”. By applying a DC (reverse) voltage across this zone will affect it. This is also called “bias” across the zone. More reverse bias results in more space, thus, causing less capacitance. In a RF circuit this can mean higher frequency, in general.

By applying “intelligence” in the form of audio (AC/voice) across the zone will cause the RF circuit to change in frequency at the same rate, thus, creating frequency modulation. The bias is set up for a fixed value to keep the voice operating in the linear range of this device. This will create good symmetry (waveform) on a frequency modulated RF carrier. This is especially true (no pun) for true/direct FM.

Special diodes are made for this purpose, called a varactor diode or “veri-cap”. They come in various specs, for capacitor ranging 5 ~ 100 pf. Typical is 10 ~ 13 pf for LMR.

Most PM transmitters have the veri-cap diode in series with the crystal causing a phase difference on the fundamental frequency, while most FM transmitters have the diode in parallel to the crystal causing a (direct) frequency change on the fundamental frequency. For FM transmitters, most have the anode to (common) ground.

FM is also used for compensation against frequency drift from temperature changes of an oscillator circuit. In some cases a transmitter uses both PM and FM for audio and compensation, respectively, or two stages of FM, for both reasons as well. Sometimes both circuits are contained (with the crystal) in one module, as in the case of the GE Mastr-II transmitter’s “ICOM”. This way the channel device (element) can be set up (compensated) for each crystal for best performance.

Frequency multiplication also multiplies the modulation of the fundamental frequency. Since this arraignment multiplies the crystal frequency 12 times it won’t take much capacitance change to obtain 5 KHz modulation (deviation) or temperature/frequency compensation, at the operating frequency.

Flat audio – The long explanation:

As previously discussed, most stock/conventional two-way radios are designed for single path operation, with it’s own pre-emphasis, deviation limiting (clipping) and receiver de-emphasis, and “forgiving” squelch operation. Each time a repeated signal occurs some reduction in signal quality happens. For multiple links (long haul) these stock radios can add gross problems, such as excessive distortion, audio frequency response being very poor and very long squelch bursts. All these conditions will cause a system to operate badly and be rather annoying and fatiguing to listen to. Fortunately, these conditions can be corrected.

Some of the problem is human ignorance, interpretation, perception and semantics when discussing audio processing (or not). To fully understand proper audio will take some careful thinking. The other point to keep in mind is the frequency range specification, such as 300 Hz ~ 3 KHz response for a conventional voice circuit, (which some would call “flat”) or 20 Hz ~ 5 KHz (which is more “flat”) or somewhere in between.

Perhaps a better explanation to clear up this argument would be to call the latter “extended flat audio” (EFA). Now, let’s go over some audio processing methods:

There are two types of audio frequency processing when it comes to FM radio equipment; which is conventional (emphasized) and flat (modified or specially designed). One of the standards for FM operation is to improve reception (audio) quality by improving the signal to noise ratio. Consider these two factors:

- Signal; meaning, the intelligence quality of voice or analog data reception.
- Noise, meaning noises from all other sources of this type of communication circuit.

Most of the noise is in the high end of a standard communication channel of 300 Hz ~ 3 KHz; also known as a voice channel. Therefore, by processing the high end of the voice channel can improve audio reception quality. This is normally done by emphasizing (increasing the level) of the high end at the originating source audio by 6 db per octave and de-emphasizing (decreasing the level) of the high end of the far end audio at the same slope.

This is a similar method to “Dolby B” technology used in stereo/hi-fi sound recordings for music listening; except its not companded (compression during recording and expansion during playback). For LMR, the far end listener will experience apparent noise reduction; thus, better S/N ratio. This method is for simplex operation since this processing is done only in the subscriber units. While this may work for a single path, repeaters and multiple links will need further understanding to produce a quality audio path.

Repeater stations:

One could use the audio from the speaker of a receiver feeding a mic. input of a transmitter. Since amateur systems can be modified without violation of type acceptance better points can be used. For example, the (flat) DPL (channel element) input is used in the case of Motorola LMR equipment. For the receiver the discriminator output is used. All receiver's discriminators should have great low-end response however, (due to IF filtering restraints) the top end always rolls off too soon. There is also the impedance-loading and level issues to deal with in some receivers. This and other SRG documents address this.

Most amateurs refer to “flat audio” with methods for a single transmitter or a single receiver to obtain quality. The key point is both components of the repeater station have to be the same of one type or the other; you cannot mix types within the same station and expect the (throughput) audio path to be flat. A repeater station with a flat receiver driving a flat transmitter will result in a flat audio path going through that type of repeater. On the other hand, a repeater station with a properly de-emphasized receiver driving a properly emphasized transmitter will also result in a flat path through that type of repeater for a standard voice channel of 300Hz ~ 3KHz. A flat repeater means the path will be transparent and not alter the audio frequency response. While some conventional station curves may have a sufficient for a single path voice transmission, most are not precise enough to be called “flat”; hence, the misunderstanding. The key point to remember is that the term “flat” should refer to path/circuit performance and not the method to obtain this.

One exception

If a repeater is truly flat for subscriber Tx to Rx path (reception) there is one exception for processing within the repeater station for “drop and insert” applications. In the case of flat equipment being used, there is a special situation where pre and de-emphasis is used in addition, to properly interface with non-radio equipment, such as a controller, voice synthesizer or the PTSN (Public Switched Telephone Network), AKA a phone patch. These sources are flat in origination therefore, need emphasizing to properly interface with subscriber (user) radios (compatible audio frequency response curve).

Deviation limiting or clipping:

Each time you limit deviation for each link in series will add more distortion. An alternative is passively repeating the audio 1:1. If you do have to limit, only do so at one point, such as the system’s controller, user signals or system output transmitter (user receive). Another option would be to set the system limit at 6 KHz and let the system user’s transmitters limit at 5 KHz deviation, to avoid audio distortion. Passive

mode requires system management and user responsibility with your adjacent "channel" neighbors. This may require some enforcement on the owner's part. There are ways to "punish" or filter over deviated (and modulated) users however, is beyond the scope of this document.

Squelch operation:

FM receivers have large IF gain. At the discriminator there is plenty of noise available during signal absence. This noise is filtered above the standard voice channel near 8-10 KHz, amplified, rectified and DC amplified to usable DC levels. The higher audio frequency range is chosen so normal traffic (voice) won't affect the squelch operation. This is known as a noise operated squelch, used in LMR-FM analog. A signal into the receiver that is stronger than the noise will "quite" the discriminator audio output, which changes the DC levels in the squelch circuit and turns on the audio amplifier to drive the local speaker for listening. A squelch circuit can also be used to key an associated transmitter; thus, making a repeater.

A twist:

Some FM systems use a sub-audible squelch system, better known as CTCSS (Continuous Tone Coded Squelch System). A carrier operated squelch can work together with a CTCSS to make either an "AND" or "OR" squelch. Companies produce repeater controllers and use this acronym in many cases. Other types of signaling (digital, etc.) can also be used to control a circuit or System. Therefore, the general term used here is "SDI", for Signaling Decode Indication (or input).

"AND" squelch means it takes both a valid carrier and valid SDI (decode) to activate the squelch. "OR" squelch means a valid SDI (tone in most cases) decode will keep the squelch open regardless of the carrier squelch setting; thus, bypassing the squelch setting. An OR squelch is not desirable for amateur use because of the (annoying) long burst of noise that occurs after the input signal stops. AND squelch is best for amateur to avoid this burst. "OR" squelch, "reverse burst" (squelch tail eliminator) and other theory of operation is discussed in another document on the SRG web site in greater detail.

Stock radio receivers have (carrier) squelch constants (time for squelch to close and mute the audio path) designed for both fixed (base station) and mobile (moving station) signals therefore, are a fairly long (200 msec.) time for squelch closure. This is noticed by a burst of noise at the end of a received transmission. For a single site this is tolerable however, for multiple links (hops) this can quickly add up to something annoying to listen to. It also slows down switching paths, causing user collisions. For links, this problem can be corrected by lowering the R/C constants in the squelch circuits; thus, shortening the squelch burst. However, if they are too low the circuits will be unstable therefore, require some careful selection, which is discussed in other documents concerning link receivers, on the SRG web site.

Links are not intended to receive mobile (moving) signals. Therefore, this squelch modification will be transparent to fixed (links) station use, which should be full quieting, strong signals. Only multiple "clicks" would be heard with this modification. The remote user (input) receivers will still have stock squelch components therefore, will provide for moving (mobile) signal changes, plus, "cover up" the multiple link clicks. The result will sound like a simple, small, single site System.

For flat audio processing there's a "cor/af board" design (by the Author) to work with most FM receivers. This board is "fixed" with soldered wires (or screws, such as the RF-IF board in the receiver). A "card" is removed simply by pulling it out, such as with the Spectra-Tac shelf. If the cor board is mounted on a card then the entire piece becomes a "card" thus, "cor card" (or module as the OEM manual calls them).

Other definitions, acronyms and other "shortcuts" are for practical reading and document space. For example, names may be truncated only after the **full name** is established. This avoids reader misunderstandings. For example, the parts list shows several manufacturers in truncated form, such as, Mouser Electronics (a major parts supplier) and may be later referred to as "Mouser" or "ME", etc.

Spokane Repeater Group:

The Author is the founder of SRG, which is a non-profit organization for the development of equipment, operation and enhancement for the benefit of other amateur radio operators doing Public Service (emergency traffic) and other hobby type discussions. <http://www.srgclub.org>



The radio - Physical Configurations:

The receiver chassis "depth" takes into account the front panel controls clearance to the panel itself (rack's rails). For the height panel sizes are identified in Rack Units (RU) with one RU being the smallest panel's height of 44mm or the standard 1 3/4". RUs are multiples of this. The width is fixed at 483 mm, or the standard 19".

- The mobile receiver will be mounted on two RUs with a depth of 170mm, or about 6 5/8".
- The "Compa" non-unified chassis receiver is three RUs, with a depth of 123mm or about 4 3/4".
- The "Spectra-Tac" receiver chassis also is three RUs but with a depth of 150mm, or about 5 7/8".

Take this into consideration if mounting a receiver in a restricted area such as a cabinet.

Bands:

Most have an intermediate frequency (IF) of 11.7 MHz. The RF-IF boards come in four VHF sub-bands:

- TLD 8271 for the 132 ~ 142 MHz band (possible use for 144 MHz repeater inputs).
- TLD 8272 for the 142 ~ 150.8 MHz band (best for 2-meter 144~148 MHz operation).
- TLD 8273 for the 150.8 ~ 162 MHz band (band change required for 2-meter use).
- TLD 8274 for the 162 ~ 174 MHz band (band change required for 2-meter use).

TLD 8272 is best for amateur work (142-150.8 MHz). For a board on another band you can change out several components, per the parts list and diagram of the OEM radio manual, starting with:

- L101 through 105, C108, 109, 110, 113 & 116 are changed to "M" range. An alternate method is to increase the length of the coils or the tuning stubs.
- Change R107 to 82K, R122 to 10K and R123 to 15K.
- The discriminator diodes, CR103 and 104 are (optionally) reversed. This is because for amateur bands; the L.O. injection is changed. More on this below.

Frequency determining devices

Most receivers (all types of chassis) normally come with a standard IF of 11.7 MHz. Most amateur band receivers 142 ~ 150.8 will use the high side channel element for the LO (local oscillator) injection to the mixer stage. This means the fundamental crystal inside the "CE" is multiplied nine times, coming out 11.7 MHz above the operating receiver frequency. The difference, of course, is 11.7 MHz for the IF.

$$\frac{\text{Operating frequency (147.800 MHz)} + \text{the I.F. (11.7 MHz)}}{9} = 17.72222 \text{ MHz}$$

Of course, adjust your figures for your frequency you plan to be on. Also, injection direction will affect the phase of detected AF at the discriminator. Therefore, the discriminator diode reversing is performed, per the OEM manual. This would be important for simulcasting or other systems not capable of correcting phase differences on the audio output. However, for most amateur use this step can be left out. If you choose to experiment with a low side injection or already have a crystal on hand for this, it's unknown if this would be successful. For this frequency in discussion, the "low side" injection results would come out as operating on 136.10 MHz. The image is two times the IF; lower than the LO. The front end will filter that out (to a certain point). Your receiver's image rejection specification is typically is 80 db down; 100 db for the micor receiver. That's one reason good receiver design uses higher IFs, like this (easier to filter out the image).

Having talked about the IF, you need to be aware some special receivers have an IF of **11.8 MHz**. These receivers are used for special interference/image problems. Therefore, the channel element you ordered for the "normal" receiver will not work for these special receivers. Keep that in mind when ordering several channel elements for your receivers.

No channel element on hand ?

If you want to check the front end's bandwidth and didn't have several crystals (CEs) to experiment with here's an interesting alternative. You will need two signal generators; one with a high level output in the 15-20 MHz range and a second conventional one operating in the 144-150 range. By using the high-level signal generator you can "replace" or simulate the crystal output.



First, find an old channel element and remove the crystal inside. Then install a 1 Meg. resistor across the crystal tabs. Then install a 30-pf cap on the left tab. That would be "left" when the channel element is sitting, with the connector pins pointing left as shown in the picture. Then connect a piece of coax's center to the other lead of this cap. Connect the coax's shield to the right tab. Drill a hole in the top of the channel element's cover. This will allow you to reassemble the channel element and plug it into the receiver's CE slot, presumably, CE1 position, with F1 enabled (grounded). The far end of the coax can be terminated with something convenient to connect to the signal generator.

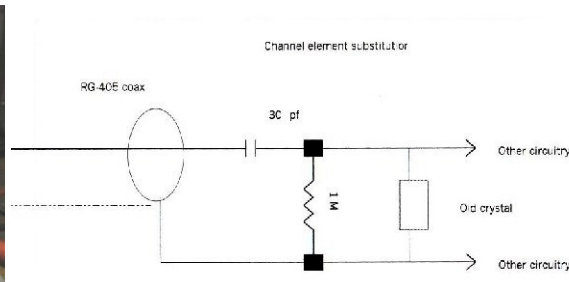
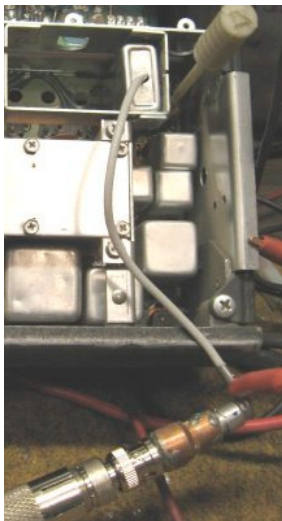

With the normal (conventional) signal generator, input the receiver's front end with a medium level, say, around an -80 dbm carrier, on the operating frequency you wish to check.

A 1 KHz modulated tone is optional at this point. It might help you "find" the signal, if you need to.

With the high-level signal generator input the (newly modified) channel element with a +10 dbm level carrier (CW), on the crystal frequency, based on the formula on the previous page. If this generator is an analog type (dial) you'll need to move the frequency around until you hear the resultant signal in the receiver's speaker (have the squelch open). That's where the 1 KHz tone might help. Once you "found" the signal you can lower and play with the first generator to find out its sensitivity.



This method is not guaranteed to produce spec sensitivity and squelch operation but will get you in the "ballpark". Using the manual's schematic remember to align the receiver properly once you obtain the proper (compensated) re-crystaled channel element for the operating frequency you plan to use. Obviously, for this document is 147.800 MHz.

Building Considerations

Before building you should understand the workings of each part of the receiver, whether it be the mobile, Compa or Spectra-Tac type. Configuration, wiring, pin-outs, I/O connections, all logic and audio levels should be standardized for easy understanding, troubleshooting, equipment replacement and alignment. . For the mobiles, the receiver chassis is kept more or less intact and mounted on a panel, with stand-offs. The cabinet rails should be up front, with enough clearance for the front controls to clear the cabinet door when closed. The chassis is offset on the panel; on the left side of the panel's edge; it comes in 1 1/4" to start the edge of the receiver's chassis. There will be six holes drilled in the chassis for the six standoffs. They are 8-32 female threads, 1" long, hex, metal type. The board's pins are removed and replaced with wires; for a custom harness. Wiring directly to the RF-IF and audio boards increases reliability but defeats the quick board replacement feature. Since mobile audio boards are not compatible with compa this was felt a moot point. "TB" (Terminal Block) on the front panel provides for all I/O connections except for the (BNC) antenna port. For the BNC connector drill a 25/64" (.390") hole, then file/ream out a little for a tight fit. Install a shielded jumper cable from it to the RCA type connector on the RF casting.

The OEM receiver had a separate "9.6v" regulator on the system board of the mobile. Therefore, a new regulator will be needed to replace that. Other installs will be the volume, squelch controls, a mode switch (CS-PL) for stand-alone packages, local speaker and a (special) audio board, AKA "COR board" designed by the Author, discussed in other SRG documents. The receiver will be a self-contained unit; you just add the antenna and 12v power.

For the "Compa", only the non-unified chassis is used for a remote receiver. Compas were widely used for many companies and government organizations. The Hospital system (H.E.A.R.) had a second receiver as well. A unified chassis however, can be used for a complete Tx-Rx unit for a single-site duplexed station. Both types came with a volume and squelch control. As with the mobile you'll need to install a (replacement) 9.6v regulator, mode switch (PL-CS), local speaker and the COR Board. If you are using the unified chassis and OEM supply the 9.6 regulator is built-in.

There is little room for the terminal block (TB) therefore, only the essential I/O connections will be installed. The same BNC connector (as in the mobile) will be a separate port. The receiver will be a self-contained unit; you just add the antenna and 12v power.

For the audio a white wire is connected from the discriminator (P904-15) to the audio board, and out to the COR/AF board. For the other wires seek the board's diagram. This board will allow an open collector (cor) PTT output with flat response from 20Hz ~ 5KHz +- 1 db or less.

If you happen to get a non-unified chassis receiver out of service from another band, such as the Author did from the VHF-Lo band, the channel element cage is located differently. Therefore, some chassis modifications were necessary. With a little help of a 4" grinder the small rivets holding them were removed.



The correct type cage (robbed from an old high-band chassis) was replaced with small bolts and nuts.



This is a general view of the finished modification with the correct boards installed.



Audio-Squelch board:

The audio-squelch board has several discrete components and two integrated circuits (ICs). You will need to know about some differences between types. For example, the IC designators are different; mobile uses "IC" while the Compa uses "U" for the two ICs on the board. The Spectra-Tac audio board uses only one IC, called "U1".

The mobile and compa versions have a plug-in daughter board that OEM calls it PL deck/board. The outputs are a DC change. While OEM calls it "PLI" for SRG projects it will be called "SDI", for Signal Decode indicator (or input). Also, OEM calls CTCSS mode "PL" while SRG standard will be called "TS" for Tone Squelch (carrier squelch will be called "CS").

The audio-squelch boards and optional PL decks between the mobile and Compa types look similar, but may not be interchangeable especially, the pin functions, so keep them organized. Of course, if you just need them for parts board (robbing) that would work for repairs. Take this into consideration when sorting out your inventory of surplus boards, before building several receivers.

Mobile version audio boards of TLN4310B or the TLN4725A audio board have the SDI, while the TLN4310A does not. For the "A" board the trace for pin 11 of P903 does not exist. However, there still is a way to bring the SDI out with a special jumper, discussed at some point (no pun). Some of the pin functions between these boards are not the same, such as P903, pin 11's function. Most of this document will cover the TLN4310x board, since it's readily available for this project.

Other features:

In the mobile, IC202 is a special IC for dual squelch operation. There are two capacitors to determine the squelch closing constant. It also has two shunt switches. Both of them are used to mute the (local) speaker audio for most versions. Pin 7 mutes the first (lower level audio) stage of IC201 at the junction of JU201 and C205. Pin 6 mutes the second (higher-level audio) stage of IC201 at the junction C210 and C211. It's unknown why two mute switches are used.

For the compa only one shunt is used for (local) audio squelching, while the other is used for a RUI (cor). In either type SRG modifications will use the one shunt for the cor output.

COR: (and some SRG history):

On the mobiles, the audio board's RUI is on pin 8 of P903 (coming from pin 10 of IC202) and the CAI is on pin 12 of P903, (coming from pin 13 of IC202). The capacitor C232 on the former could slow the output response. For mobile accessory group features (such as the call light, etc.) this point is satisfactory, however, may be too slow for RF links. This logic change needs to happen quickly. Past SRG remote receivers have used these COR points by reducing or removing these capacitors, where needed. Past SRG receivers used a "COR" point in place of the RUI. In the past pin 7 was removed from the audio circuit and appeared to be the best COR point to use. Since the "pull down" 47K resistor, R225, would unnecessarily pull the active voltage down, it was removed. A pull-up resistor was added on the board to produce a positive going active signal. However, this changed in 2018 from more information discovered therefore, the pull-down is left intact for future builds. This is covered in a (separate) document on SRG's web site, called "squelch and tone". Review the "Spectra-Tac" document, too.

The TLN4310A (old version) board will no longer be covered in future documents. However, several versions ended up for SRG projects including the (old) "A" board. For example, the TLN4310A used pin 7 of IC202, while B board used pin 6, except for version C. This happen because of research and development was postponed during a build-out of the repeater, which required fast deployment of remote receiver/downlink packages over the past two decades. Future research of 2010~13 determined the cor methods are narrowed down to one version for the mobile and one version for the station. These will be indicated at the end of the discussion in bold text. The diagrams of different versions, including the TLN4310A is for support only. They also may help you, if you wish to set up your receiver differently.

- Mobile Stock:

Cor point from P903, pin 12 is the CAI. Adjust the cor point on the COR/AF Board version 5.3 for proper logic change. It's questionable if the CAI is quick enough for link operation. Presently, some SRG receivers that have this arrangement may be changed to one of the other following versions.

- Mobile Version A:

As previously discussed, the COR point comes from one of the shunts on IC202. For this version with the TLN4310B board pin 7 of P903 (pin 6 of IC202), is the cor output. Move the right lead of C211 to the eyelet of R225. Move the right lead of R208 down on it's run slightly. Move C210 to the right eyelet that R208 was in. Put the other lead of C210 with R225 and C211. That will be three leads in the same hole so you'll need to rim it out a little. Remove the (stock) jumper from P903 pin 7 eyelet and P903 pin 10. It's located between the board edge and IC 202. Install a new jumper between P903 pin 7 and where the right lead of C211 was.

This is a shunt to partial ground) during standby and active going relaxed. With a pull-up resistor on the (external) COR/AF board produced an active going high cor. If you are not using the cor/af board install a

pull-up at a convenient point to feed your controller. To disable the PL filter function remove pins 4 and 5 of P201. JU201 is in, since local speaker monitoring/testing is full-range and on carrier squelch).

- Mobile Version B:

For this version with the TLN4310B board pin 7 of P903 (pin 6 of IC202), is the COR output. Remove the right lead of C211. Remove the lower lead of C210. Remove the upper lead of R226. Then make a flying tie joint with all three of these (pulled) leads from the three components. Remove the (stock) jumper from P903 pin 7 eyelet and P903 pin 10. It's located between the board edge and IC 202. Install a new jumper between P903 pin 7 and where the right lead of C211 was.

This is a shunt to partial ground during standby and active going relaxed. With a pull-up resistor on the (external) COR/AF board produced an active going high cor. If you are not using the COR/AF board install a pull-up at a convenient point to feed your controller. To disable the PL filter function remove pins 4 and 5 of P201. JU201 is in, since local speaker monitoring/testing is full-range and on carrier squelch).

- Mobile Version C:

For this version with the TLN4310B board pin 7 of P903 (pin 7 of IC202), is the COR output. Remove the lower lead of R225 and install it at the right lead of C205. Either share the hole (rim out) or make a new one right next to it. Cut the run between the new and old location of R225's lead. Remove the (stock) jumper from P903 pin 7 eyelet and P903 pin 10. It's located between the board edge and IC 202. Install a new jumper between P903 pin 7 and where the old, lower lead of R225 was.

This is a shunt (to partial ground) during standby and active going relaxed. With a pull-up resistor to produce an active going high COR. Previous versions had the pull-up on the cor board. In the event the TLN board cor lead was removed it would activate the external cor/af board. This is especially true with the Spectra-Tac version on carrier squelch; by pulling the audio control card would key the downlink transmitter. Therefore, future builds will have the resistor at the source and not on the external device. To disable the PL filter function remove pins 4 and 5 of P201. As previously mentioned, JU201 is in. Version **C** is used for all future **SRG** projects. As mentioned earlier, there's a change in 2018 about the pull-up to resistance use. Seek the document "Squelch and Tone" on SRGs web site for details.

Stations: (compa)

Presently, there are two SRG modifications for the "Compa-station" that uses the TRN6006, TRN6007A or TRN5363A audio-squelch board for carrier squelch receivers. The TRN6002A PL deck (and reed) are also used for the tone receivers.

U202 is the special IC for dual squelch for the Compa type. Only one shunt is used for (local) speaker mute. Pin 7 mutes the first stage of U201 at the junction of JU201 and C206. This apparently is enough to mute the speaker audio. From older SRG construction it's possible this pin-7 shunt line was moved to the second audio stage as in the case of the Wenatchee receiver documentation. Future design will leave the shunt in the stock arrangement.

SRG's cor point does not use the CAI but uses the RUI. However, the RUI is a different arraignment from the mobiles that does not use pin 10 of U202 (with the capacitor across it). It comes from pin 8 of P903 (coming from pin 6 of U202).

Therefore, the station RUI provides a shunt (to partial ground) during standby and a relaxed emitter type during activity. In the past it did not have any pull-up or down resistor either. It's also assumed this RUI is connected (through the mother board/back plan) to the station's control shelf, presumably, for a "repeater squelch gate" card function. Plus, no audio board modifications are necessary (for one version) with a fast logic change to signal a controller or link transmitter or when using the cor board.

- Compa Version A:

This is a shunt (believed to be to ground) during standby and active going relaxed. With the pull-up resistor on the board will produce an active going high cor. There are no board cuts. To disable the PL filter remove pins 6 and 8 of P201. As previously mentioned, JU201 is in. Version **A** for the Compas are used for all future **SRG** projects.

- Compa Version B:

If you feel compelled for another way version B is acceptable for most configurations however, has not been verified or tested. For this, cut the run between U202, pin 7 and C206. Best place for the cut is just above C213. Then solder a bridge from the pin 7 side of this run to the right lead of C213.

This is a shunt (believed to be to ground) during standby and active going relaxed. With the pull-up resistor on the board will produce an active going high cor. If you are not using the cor board install a pull-up at a convenient point to feed your controller. To disable the PL filter remove pins 6 and 8 of P201. As previously mentioned, JU201 is in.

“AND” squelch:

For receivers being set up for tone mode will use the (stock) TLN4294A/B (mobile) “PL deck”. DC logic output (old term of PLI) affects the squelch IC IC202 (or U202) pin 8, making it an “OR” squelch. It also affects the local speaker operation. For amateur use, “OR” squelch is not good so you need to change the tone receiver to “AND” squelch (carrier + tone). For each type and version of receiver is a different way to accomplish this. For the mobile (new and old) you may find a jumper, or not; if not, cut the run going to IC202, pin 8. For the compa's audio squelch board, there's a jumper (JU204) to be left out. For the Spectra-Tac's audio control module, the jumper JU1 is to be left out. There's more discussion about this later on a separate document on SRG's web site. There is also a separate document concerning an “AND” squelch. An external decoder can be used as well.

PL Deck:

The stock deck uses the “vibersponder” (not the “sender”). For all versions, the stock PL deck's output is a PNP switch (collector) output. During standby it's turned off; so no voltage output. During a valid decode it turns on producing a forced “high” output. CS or PL mode can be controlled either by the front panel switch or TB1 terminal. Control is standard Motorola “closed loop”: whereas, a low to ground enables PL mode. However, for the Spec-Tac receivers using external interface (control) this will be different. There are some version differences on these board such as the TLN4294A, B and the TRN6002A. Drawings for these boards are near the end of this document.

Local audio:

For the mobile version there's a speaker mounted to the chassis for local audio listening with a panel switch to turn it on and off. There's a front panel (flashing) indicator to remind you when it's on. When you leave the site, its good practice to leave it off as a curtsey. Leaving it on (24/7) at the site is an annoyance to others working there. The Spectra-Tac version only has a (600-ohm) line driver to use as local audio therefore. If a medium impedance speaker cannot be found a transformer can be used.

The volume control affects the local audio, which is always on carrier squelch, de-emphasized and designed to drive a (low impedance) speaker. It's output is balanced, however, can be easily made single-ended by grounding the “speaker low”. This is shown on the interface drawing's terminal block which is also a good (audio) point to measure sensitivity or drive an external device requiring de-emphasize audio. Turning on the local speaker switch can change this level. To correct this, a 15 ohm, 1-watt (load) resistor is installed on one pole of the switch to keep the level from changing. This is for the mobile or compa version. For Spectra-Tac seek the separate document.

During standby mode you can check for receiver noise by pushing the “monitor” button on the panel. This avoids changing the squelch (pot) setting. It's similar to the GE MVP “monitor” slide switch. It puts a 100 ohm* resistor from the squelch wiper to ground to disable the squelch. When you do this will activate the

PTT output as well for a CS receiver but not a PL one. Only a valid signal (carrier + tone) will activate the PTT in the case of a PL receiver. Or flip the mode switch to CS.

Tone receivers that use the stock "PL deck" have a high pass filter. This is disabled by removing pins 4 and 5 on P201's mobile type, or pins 6 and 8 on P201's Compa type and keeping JU201 in on the audio board. Full range local audio is useful for testing and monitoring user-input signals.

There's some other handy LED indicators are installed on the front panel, such as SDI, PTT out active and 9.6v power. The reasoning with the 9.6v indicator is that it shows both 12v and 9.6v is operational, since the former supplies the latter. Also, a panel-indicating fuse protects from an overload on the 12v input side. In the event it's blown, a panel indicator alerts the technician. The Spectra-Tac version does not use this type of indicator, but uses both voltage indicators in the 2018 build. Future versions will only have the 9.6v indicator.

Front Panel controls:

The volume and squelch controls are mounted on the front panel for mobile and Compa types. There's some options here. Conventional knobs can be used for best convenience. This is satisfactory in enclosed cabinet arrangement. For open rack mounts, a short shaft, screwdriver adjust may be an alternative to avoid bumping them from their settings. This also discourages benign tampering of these controls. A third option for the mobile mount is to leave the volume control on the front panel so, one can't "hurt" something and hide the squelch control inside for example, near or on the cor board. However, the volume control may be an important setting if used to drive an external device.

Other modifications:

For the mobile, a 7810 regulator is installed on the IF board, with a 4-40 bolt in the hole for F4 frequency adjust, with the leads going to the pins of F3; pin 3 for the input and pin 2 for the output, with a common diode in series to drop the 10v+ to 9.4, which is close enough for the stock "9.6v". Part of it can be seen in the lower left section of this image. This run also connects to the rest of the supply "9.6 switched" on the board. An orange wire straps this to the "9.6 continuous". A red wire connects to the "A+" and to F3 select, which is now used for the regulator input. Shown is the local speaker and cor board installed.

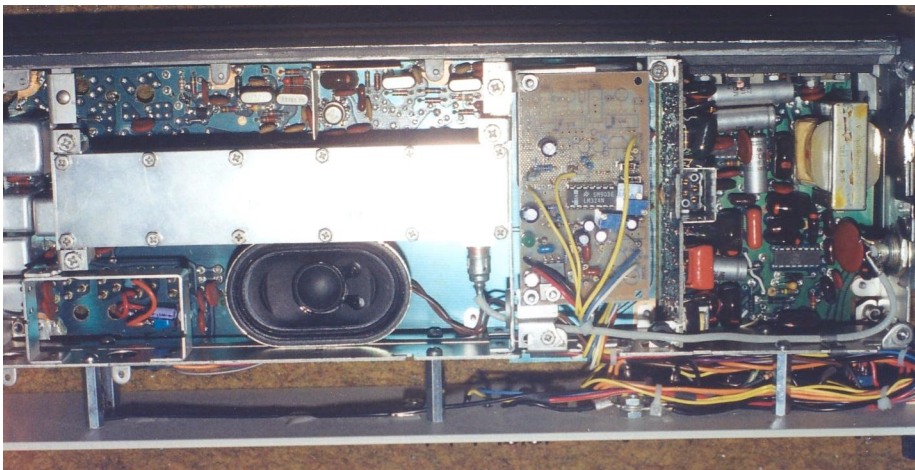

The following pages show diagrams for the different versions of PL decks:

- TLN4294A and B schematic
- TLN4294A and B board layout
- TLN4294B schematic
- TLN4294B board layout
- TRN6002A schematic
- TRN6002A board layout earlier version
- TRB6002A board layout later version

"PRIVATE-LINE" DECODER AND FILTER BOARD

TLN 4294A AND B

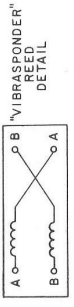
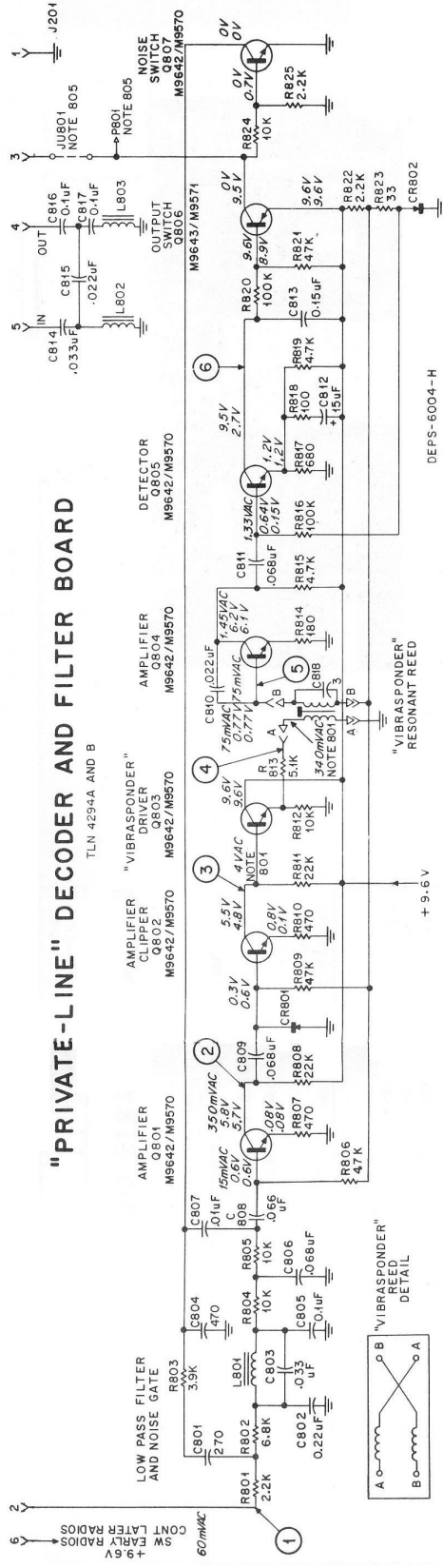

DEFS-6004-H

TLN 4294 A and B

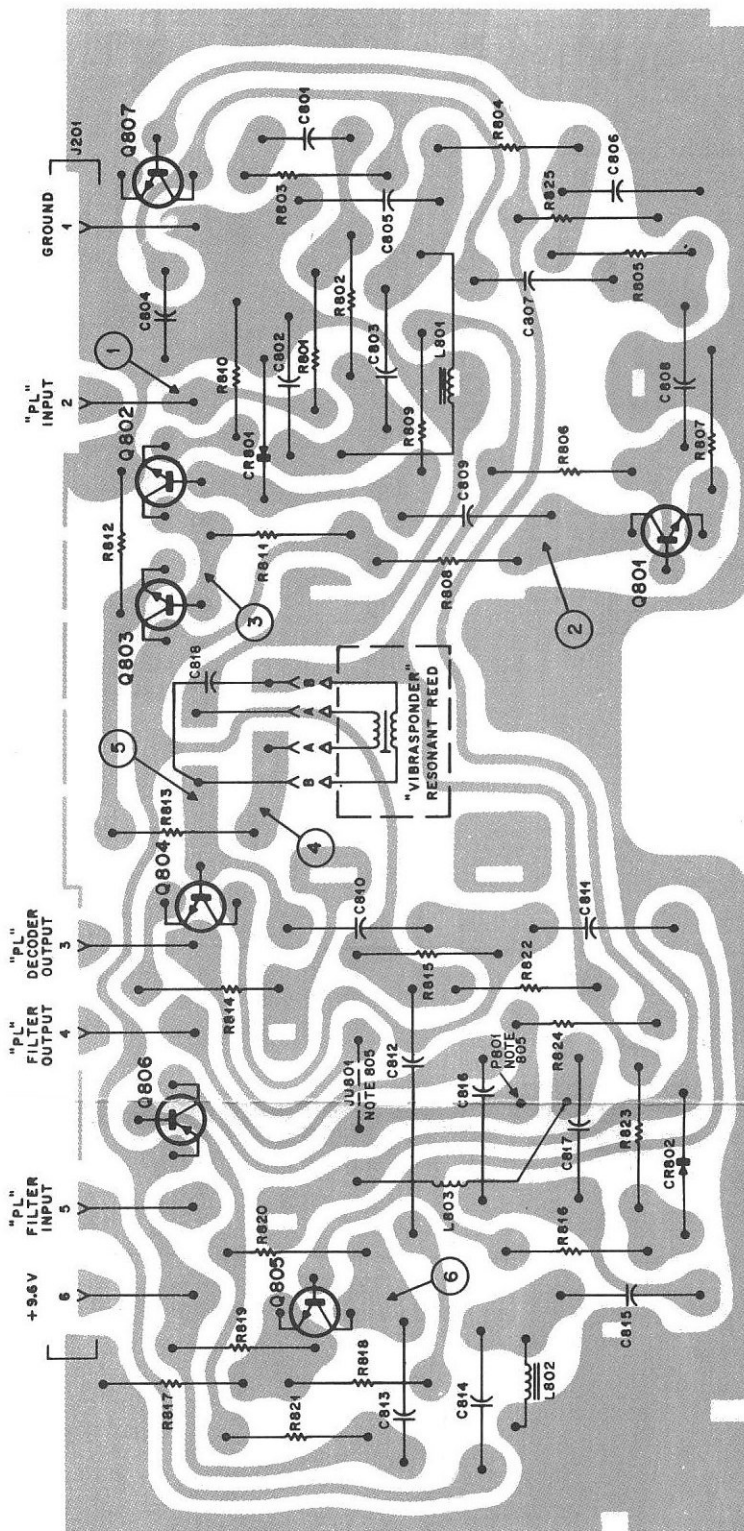

SHOWN FROM SOLDER SIDE

"PRIVATE-LINE" DECODER AND FILTER BOARD

UN4294B

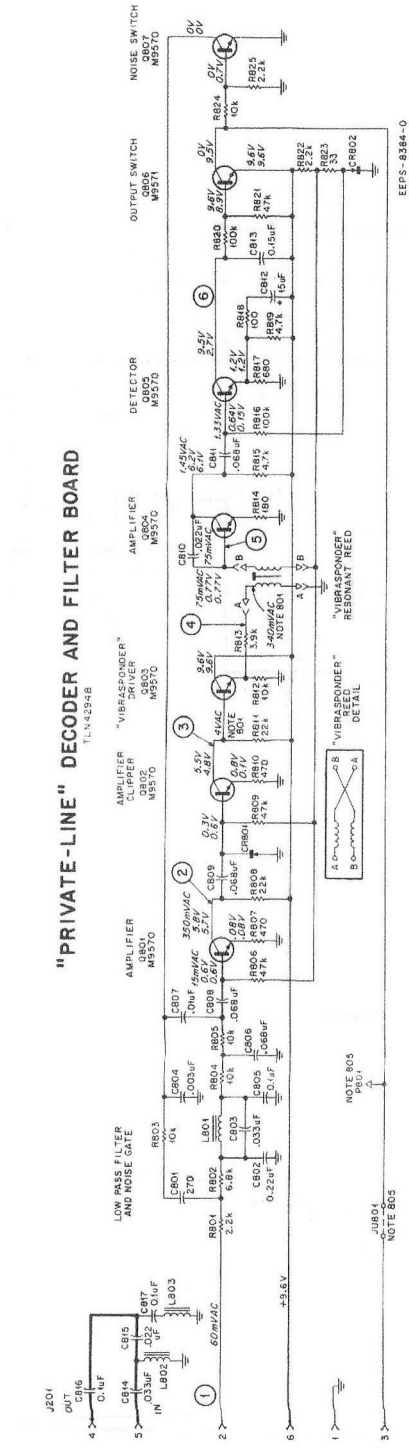

TLN4294B Layout

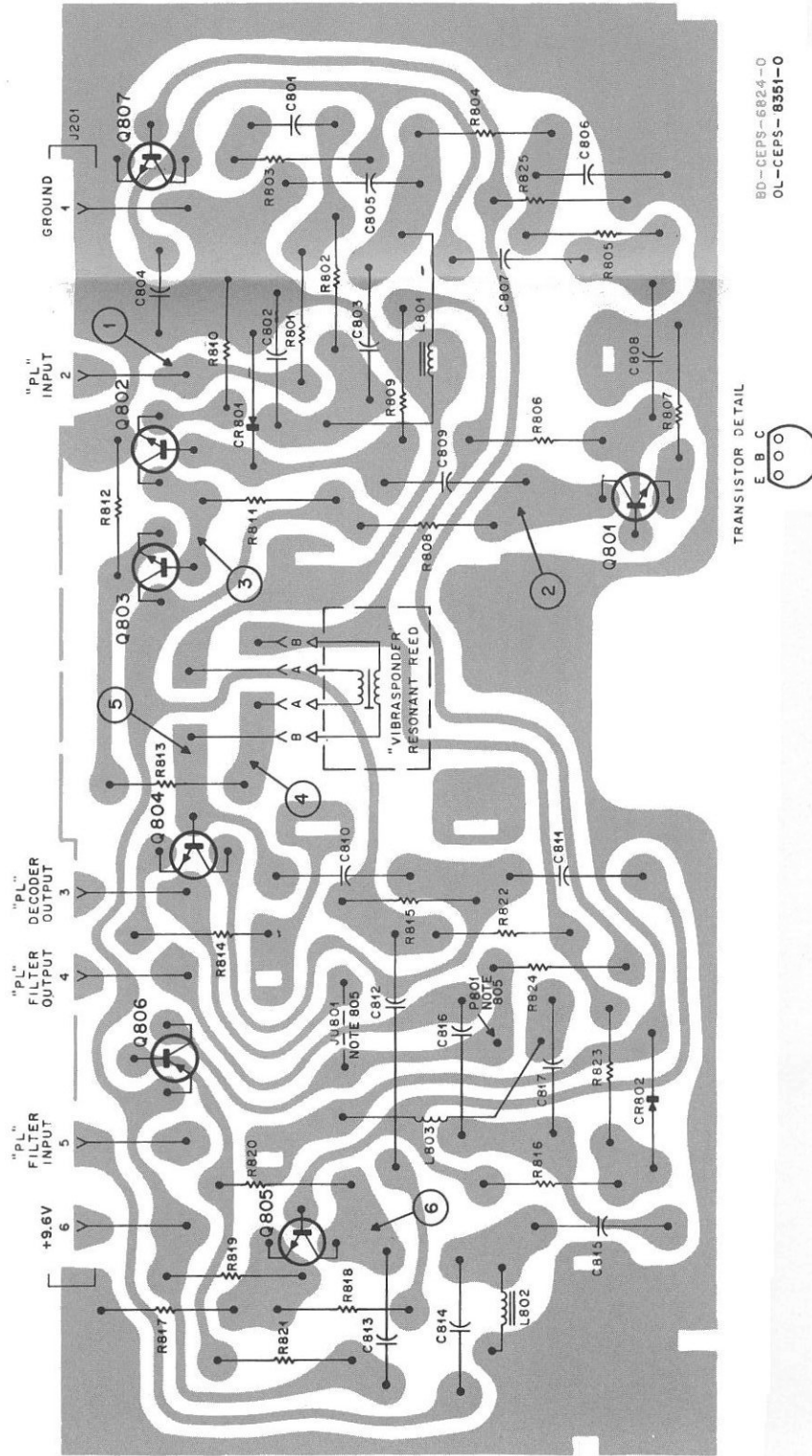

BD-CEPS-6824-0
OL-CEPS-8351-0

TRANSISTOR DETAIL

E B C

TONE "PRIVATE-LINE" DECODER

TRN6002A

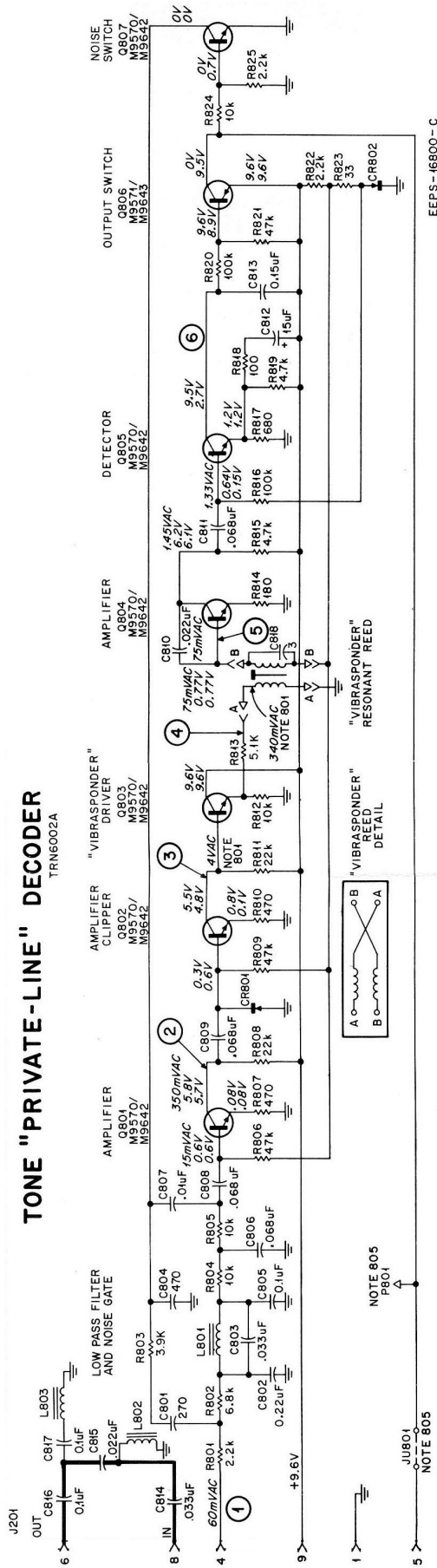

EEPS-16800-C

TRN6002A earlier version

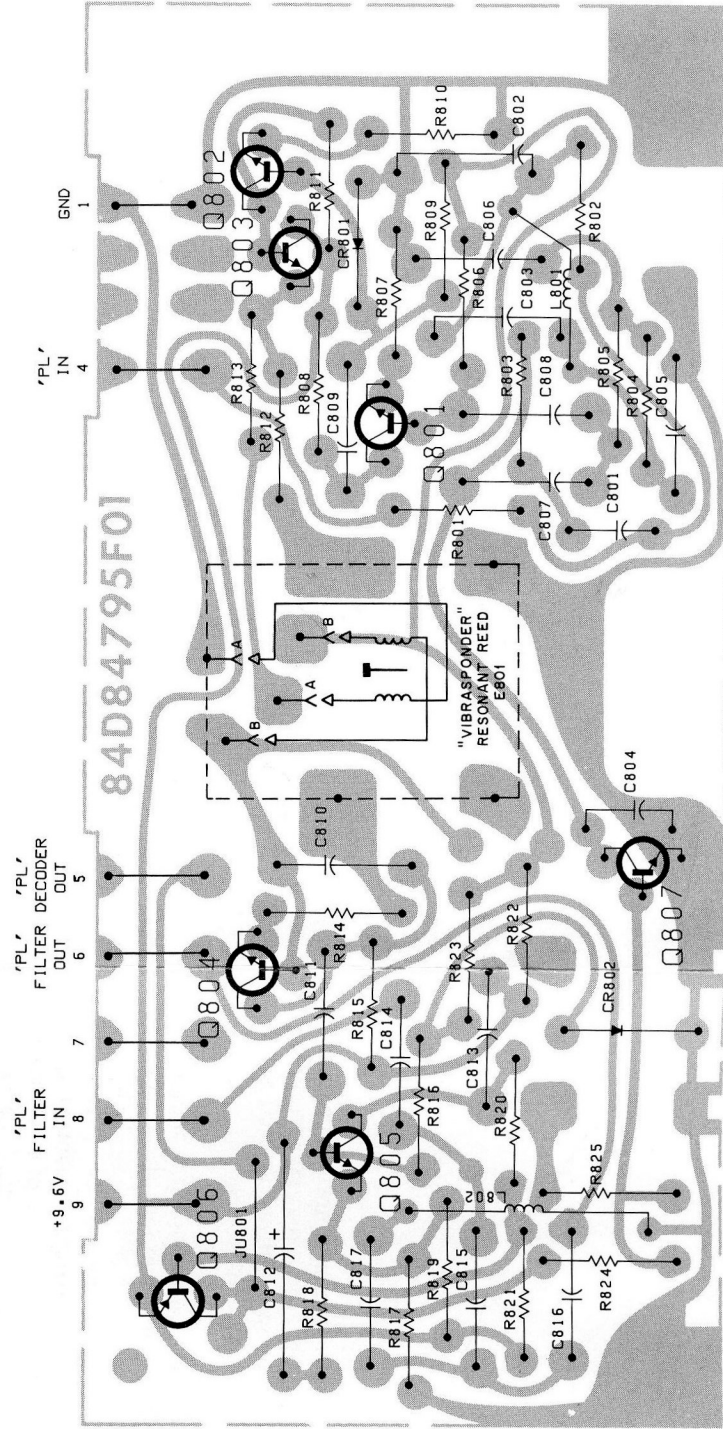

SHOWN FROM SOLDER SIDE

BD-CEPS-16801-A
OL-CEPS-16802-B

TRN6002A later version

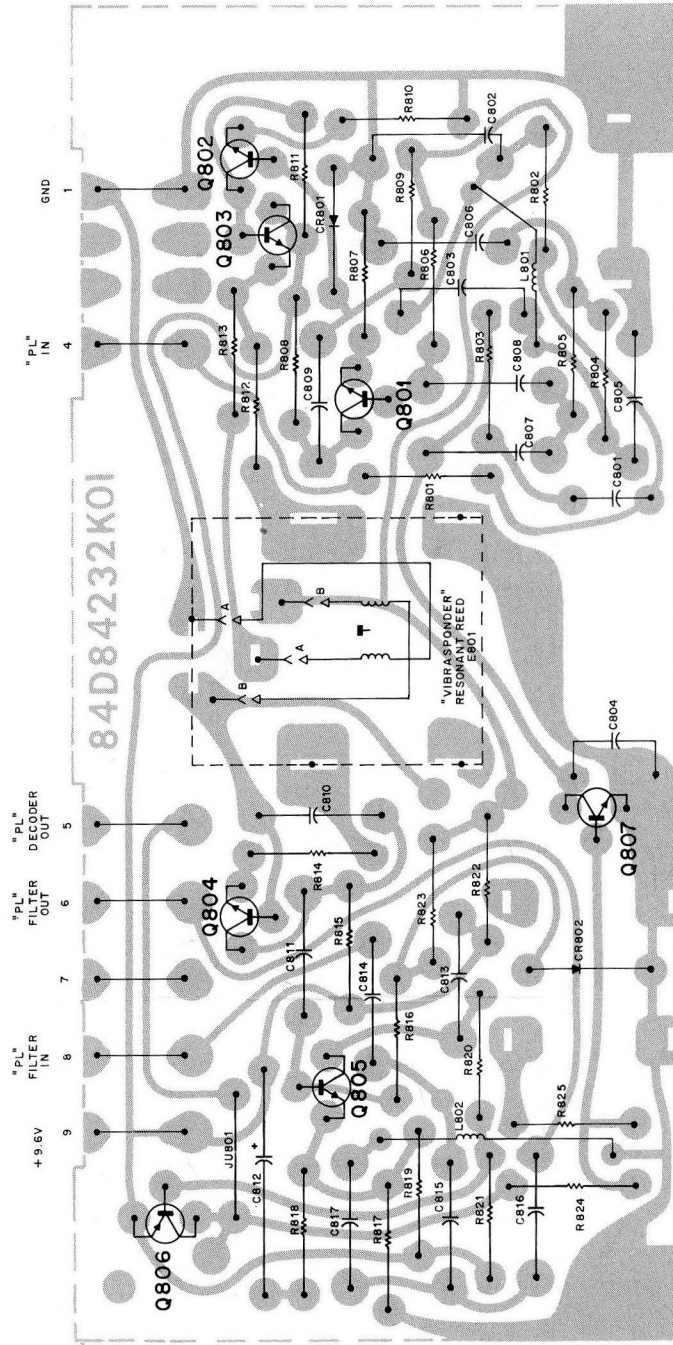

BD-CEPS-21107-0
OL-CEPS-21108-0

SHOWN FROM SOLDER SIDE

In the event you need to replace the front controls on a "compa" type chassis, here's the diagram:

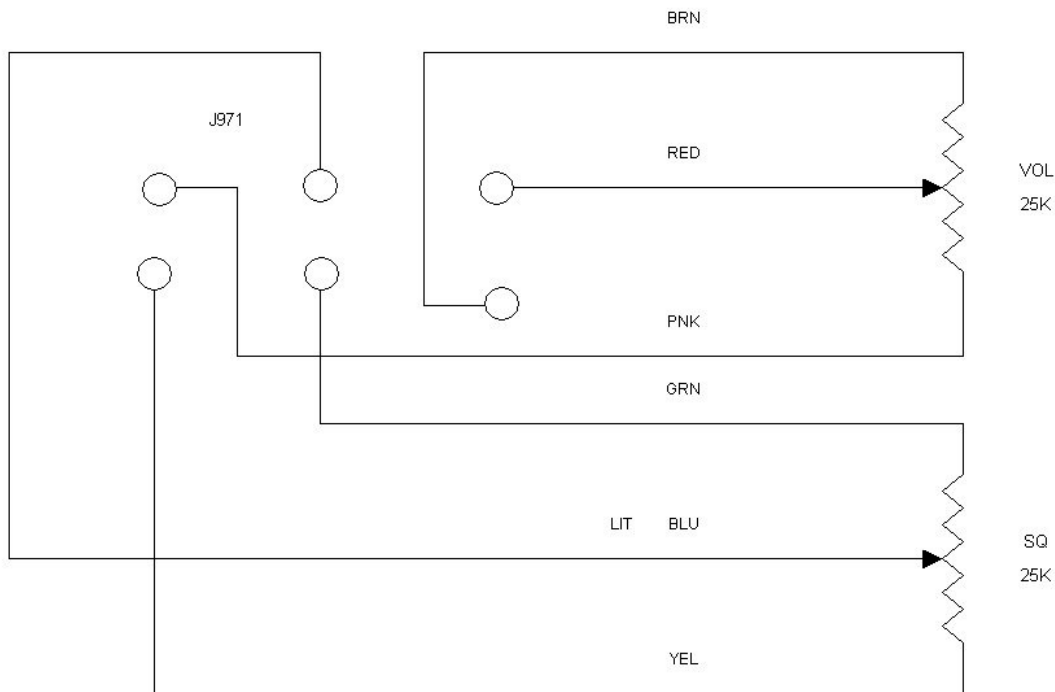

NOTES:

Volume and squelch connections

OEM pn:18-82515B50

This is for the "compa" stations

Solder side view (interconnect bd)

Design and Drawing by Karl Shoemaker

Parts list for band change and other changes: (for mobile type receiver):

- 1 19' rack panel #2; Bud radio # PA-1102-WH
- 6 standoffs, 1/4" hex body, 8-32 female threads
- 6 machine screws PPH 8-32, 1/2"
- 6 machine screws PPH 8-32, 1/4"
- 1 COR/AF board Ver. 5.3
- 2 25K LT pots w/switch
- 1 n.o. push button
- 1 LED, red
- 2 10K resistor
- 2 1K resistor
- 1 4.7 K resistor
- mics wire for hookup around 22 gu, various colors, black, red, yellow, etc
- some heat shrink to wrap the above wires as a harness
- 1 terminal block 140-14 (14 position)
- 1 matching transformer, 1K CT / 8 ohm, Radio Shack 273-1380 (use the 500 ohm tap).

For all type of receivers:

- Micor front end parts list for conversion to "M" (142-150.8 MHz)
- 21-82133G29 C108 18 pf * (SRG used 21-82133G58, 27pf, in some builds)

21-82610C44 C109 47 pf * (SRG used 21-83406D44, 47 pf, in some builds)
21-84494B03 C110 80 pf
21-82133G14 C113 7.5 pf
21-82133G14 C116 7.5 pf
24-84070C01 L101 (w/tap)
24-84070C03 L102
24-84070C03 L103
24-84070C03 L104
1-80713B52 L105 (w/tapped black wire)
Change R107 to 82K (SRG builds declined)
Change R122 to 10K (SRG builds declined)
Change R123 to 15K; (SRG builds declined)
Reverse CR102 and CR104 (because of high side injection, now) (SRG builds declined)

Notes: On the front end coils this range, the windings are closer and more of them (about 7 windings). On C109 there is some differences on the value should be used, in some of the older manuals. Keep that in mind when making the LO multiplier stages to work with a fundamental crystal around 17 MHz.

* In the case of the (old) "Omak Rx" a 10-ohm was used for the monitor function. (replaced now.)

Jumper chart:

JU201 IN
JU202 OUT
JU203 OUT
JU204 OUT

NOTE: This project may become obsolete for SRG. The remaining 2RU panel mount receivers will remain in service for their life. In the event of repairs they would be swapped out with the Spectra-TAC version of receiver. See that document for relevant information on SRG's web site.

This document may be used for amateur purposes with the Author given credit for it's content. This document may be printed and passed on to other amateurs, with the understanding not to modify or change the content of the document without the Author's permission. Notifications of typos or errors are welcome.

Document setup notes: Font: arial 10, margins: top: .7", bottom: .9, left and right 1.0, header: .2, footer: .7"; portrait. Images: float over text and most are square positioning. AK2O with updates on April 2015, December 2015, April 2016 and May 2016, January 2017, February 2017, March 2017, June 2017, March 2018, May 2018, Jan 2020, July 2023.

